

# CleanLine™ ASE Filter and Laser Systems

Ondax CleanLine™ Series ASE Filter Systems are a family of tightly integrated, pre-aligned, multi-element ASE Filter Modules and lasers designed to provide the enhanced narrow band, low noise, ASE-free laser performance required for ultra-low-frequency Raman spectroscopy, and other demanding spectroscopy or metrology applications. Configured for fast, easy alignment and use with our SureBlock™ XLF Series Raman Filter Systems, the CleanLine™ family is based on our proprietary NoiseBlock™ solid-state, ultra-narrow band Volume Holographic Filter technology, delivering unlimited lifetime, exceptional throughput, and ultra-stable environmental performance.

The CleanLine™ FS free-space filter system is an ultra-compact (3" or 75mm) filter system with integrated alignment irises and a built-in wavelength fine-tuning adjustment. The CleanLine™ LM-FS incorporates a SureLock™ LM Series wavelength-stabilized laser module along with a CleanLine™ FS. And the CleanLine™ LM-FC includes an optical isolator and various fiber-coupling options – making the CleanLine™ easily configurable for turn-key integration into your experiment, instrumentation, or Raman spectroscopy system.

Available for standard wavelengths of 785nm, 532nm, and 405nm. Custom wavelengths are available upon request.

## Specifications:

Specification <sup>1</sup>	units	405nm	532nm <sup>1</sup>	785nm
ASE Suppression (below laser line), typical	dB	-80	-80	-80
Throughput <sup>1</sup> (FS version), minimum/typical	% of incoming power	55/60	65/70	70/75
Temperature Stability	pm/°C	10	10	10

<sup>1</sup> CleanLine FS Only. Throughput specifications do not include isolator or fiber coupled versions. Call for specifications on specific wavelengths or configurations.

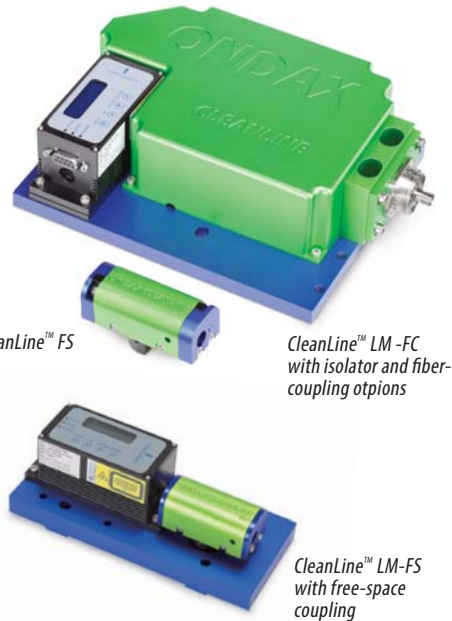

## Features:

- Exceptional ASE suppression – better than -80dB below laser line
- Stable, ultra-narrowband performance – 0.1nm bandwidth,  $\Delta\lambda = 10\text{pm}/^\circ\text{C}$
- Compact, pre-aligned packaging – free space or isolated/fiber coupled configurations
- Fast, easy alignment and integration with SureLock LM lasers and XLF Series Raman Filter Systems
- Convenient built-in alignment irises and wavelength fine-tuning adjustment (FS version)

## Applications:

- Ultra-low frequency Raman spectroscopy
- High resolution metrology/spectroscopy

# CleanLine™

## Exceptional Suppression of ASE Light

Adding a CleanLine™ ASE Filter System conserves up to 80% of the single frequency line, while reducing ASE noise to less than -80dB. The resulting beam is perfectly matched to Ondax SureBlock™ Notch and XLF-Series ultra-narrow band filters and filter systems.

## Mechanical Drawings

CleanLine-FS

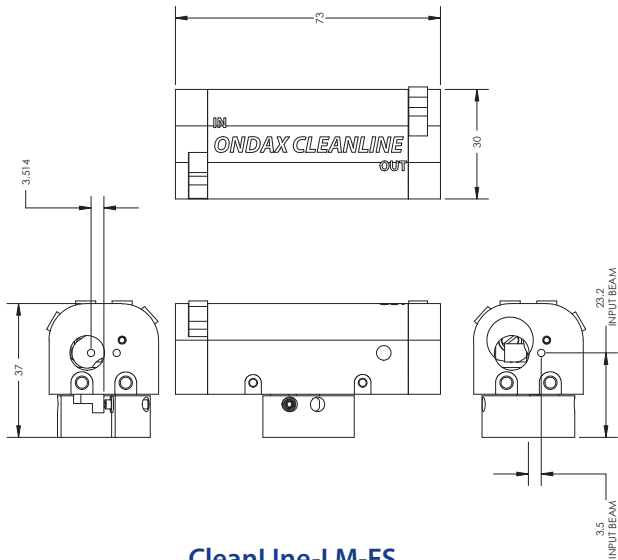

CleanLine-LM-FS

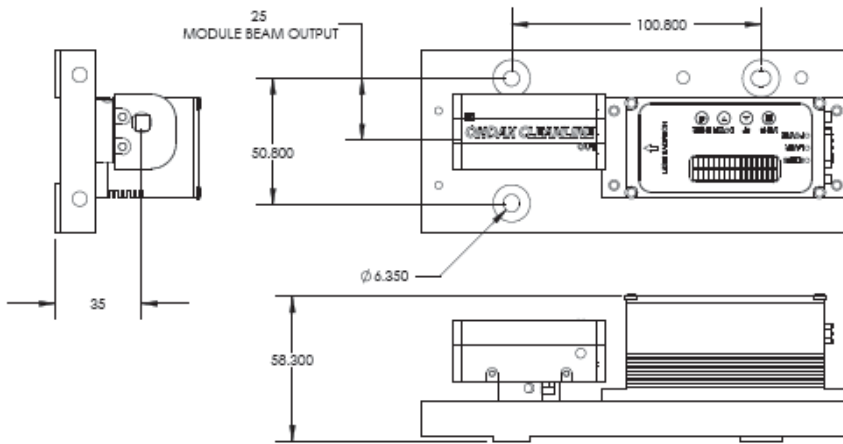

CleanLine-LM-FC

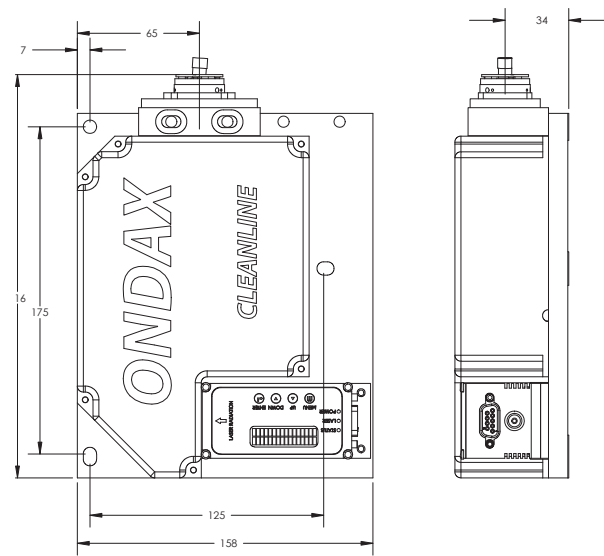

\*Dimensions in millimeters

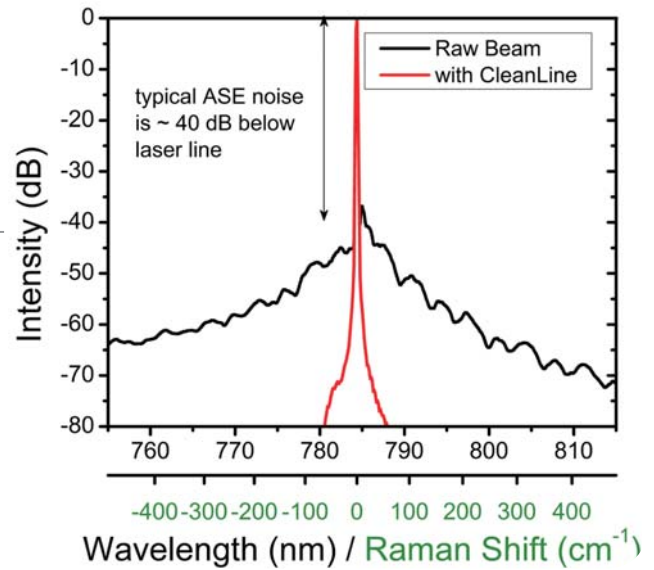

Example ASE reduction on SureLock 785nm laser module.  
CleanLine reduces residual ASE noise to less than -80dB

## Ordering Information

CleanLine-FS- $\lambda\lambda\lambda.\lambda$

$\lambda\lambda\lambda.\lambda$  = Wavelength (nm)

CleanLine-LM- $\lambda\lambda\lambda.\lambda$ -AA

$\lambda\lambda\lambda.\lambda$  = Wavelength (nm)

AA = Output option:

FS=Free Space, IS=Free Space+Isolator, FC = FC/PC, SM = SMA, AP = FC/APC



850 E. Duarte Rd. Monrovia, CA 91016  
626-357-9600 (Tel)  
626-513-7494 (Sales Fax)

**PNEUM Co., Ltd.**

5-15-3 Minamikoshigaya, Koshigaya-shi,  
Saitama-ken, 343-0845, Japan

TEL: 81-48-985-2720

FAX: 81-48-985-2721

info@pneum.co.jp 1506

For more information about Ondax products and the name of a local representative or distributor, visit [www.ondax.com](http://www.ondax.com), email [sales@ondax.com](mailto:sales@ondax.com), or call (626) 357-9600. Specifications subject to change without notice. Each purchased laser is provided with test data. Please refer to this data before using the laser.

© 2014 Ondax, Inc. - Rev. 3